

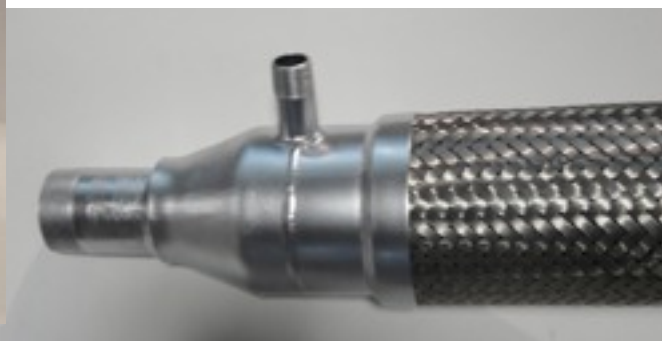

Midwest Flexible Hose, Inc.

M
e
t
a
l

H
o
s
e



Phone: 800-642-4673

Fax: 262-781-2398

e mail: tom@midwestflexiblehose.com

5181 N. 125th St., P.O. Box 249

Butler, WI 53007

Table of Contents



Category		Page
SERIES - LW	Light Weight Hose	4
SERIES - EF	Light Weight "Extra" Flexible Hose	5
SERIES - MW	Medium Duty Hose	6
SERIES - HD	Heavy Duty High Pressure Hose	7
SERIES - HDX	Ultra High Pressure Hose	8
SERIES - BB	Bronze Hose	9
UL LISTED HOSE	Stainless Steel Hose Assemblies	10
Corrugated Metal Hose Fittings		11-12
Protective Hose Coverings		13
Selection Criteria		14
Offset Chart		15
Temperature Adjustment Factors		16
Pressure and Motion		17
Traveling Loops		18-20
Do's and Don'ts		21
Interlocked Flexible Metal Tubing		22



LIGHT WEIGHT HOSE

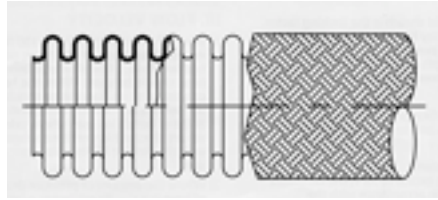

SERIES - LW Stainless Steel Hose

Construction: Annular/Standard Pitch/Close Pitch
 Characteristics: High Flexibility

Material: Hose: T321, T316L
Braid: T304L

NOM. I D (IN.)	PART #	BRAID LAYERS	NOM. O D (IN.)	Max. Pressure @ 70°F(PSIG)			Bend Radius (IN.)		WEIGHT PER FT. (LBS.)
				WORK	TEST	BURST	DYNAMIC	STATIC	
1/4"	LW - 004	0	.38	72	108	----	3.15	1.1	0.05
		1	.43	2,360	3,540	9,440			
5/16"	LW - 005	0	.48	72	108	----	4.85	1.23	0.05
		1	.53	1,647	2,470	6,588			
3/8"	LW - 006	0	.56	72	108	----	5.08	1.52	0.07
		1	.62	1,639	2,458	6,556			
1/2"	LW - 008	0	.66	72	108	----	5.47	1.75	0.08
		1	.72	1,225	1,837	4,900			
5/8"	LW - 010	0	.85	71	107	----	6.28	2.21	0.12
		1	.92	1,200	1,800	4,800			
3/4"	LW - 012	0	1.05	43	65	----	6.58	2.65	0.19
		1	1.12	1,034	1,551	4,136			
1"	LW - 016	0	1.27	43	65	----	7.5	3.33	0.24
		1	1.34	796	1,194	3,184			
1-1/4"	LW - 020	0	1.62	43	65	----	10.2	4.1	0.33
		1	1.69	600	900	2,400			
1-1/2"	LW - 024	0	1.95	28	42	----	11.75	5.08	0.51
		1	2.03	557	835	2,228			
2"	LW - 032	0	2.38	28	42	----	12.55	6.27	0.64
		1	2.48	570	855	2,280			

LIGHT WEIGHT "EXTRA" FLEXIBLE HOSE

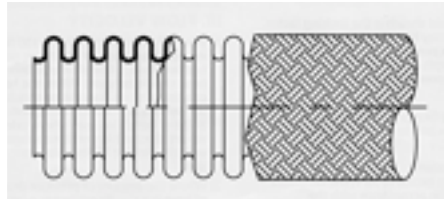

SERIES - EF

Construction: Annular butt welded, hydro formed closed, pitched hose

Characteristics: Extremely flexible - ISO 10380 conformance, 50,000 cycle rated and pressure rated per ISO 10380. Hose is designed to meet the most strenuous conditions.

Material: Hose: T321, T316L Stainless Steel
Braid: 300 Series Stainless Steel

NOM. DIAMETER (IN.)	PART #	NUMBER OF BRAIDS	NOM. O D (IN.)	STATIC		DYNAMIC		BURST PRESSURE @ 70°F(PSIG)	WEIGHT PER FT. (POUNDS)
				MINIMUM BEND RADIUS (IN.)	MAXIMUM WORKING PRESSURE @ 70°F (PSIG)	MINIMUM BEND RADIUS (IN.)	MAXIMUM WORKING PRESSURE @ 70°F(PSIG)		
1/4"	EF - 004	0	.39	.35	392	----	----	----	.04
		1	.45	.75	4,829	5.50	2,030	11,165	.12
3/8"	EF - 006	0	.63	.55	174	----	----	----	.09
		1	.70	1.14	3,727	6.00	1,450	8,004	.23
1/2"	EF - 008	0	.73	.83	131	----	----	----	.10
		1	.79	1.34	2,973	4.88	1,160	6,104	.24
3/4"	EF - 012	0	1.11	1.26	32	----	----	----	.15
		1	1.18	2.09	1,421	6.65	725	3,509	.36
1"	EF - 016	0	1.37	1.46	26	----	----	----	.20
		1	1.43	2.52	972	7.68	580	2,755	.44
1-1/4"	EF - 020	0	1.71	1.81	22	----	----	----	.33
		1	1.79	3.11	1,131	8.86	580	2,973	.68
1-1/2"	EF - 024	0	2.06	2.16	17	----	----	----	.40
		1	2.14	3.86	885	10.04	465	2,465	.88
2"	EF - 032	0	2.55	2.56	13	----	----	----	.64
		1	2.65	4.72	928	11.54	465	2,436	1.35



MEDIUM DUTY HOSE

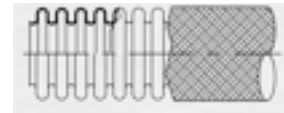

SERIES - MW Stainless Steel Hose

Construction: Annular/Standard Pitch

Characteristics: Medium Weight/Medium Flexibility

Material: Hose: T321, T316L

Braid: T304L

NOM. I D (IN.)	PART #	BRAID LAYERS	NOM. O D (IN.)	Max. Pressure @ 70°F (PSIG)			Centerline Bend Radius (IN.)		WEIGHT PER FT. (LBS.)
				WORKING	TEST	NOM. BURST	DYNAMIC	STATIC	
1/4"	MW - 004	0	.48	180	270	----	--	--	.09
		1	.57	2,116	3,844	8,464	5.00	1.00	.17
		2	.64	3,125	4,687	12,500	--	--	.26
3/8"	MW - 006	0	.63	100	150	----	--	--	.13
		1	.70	1,501	2,251	6,004	5.50	1.25	.25
		2	.81	2,401	3,602	9,604	--	--	.36
1/2"	MW - 008	0	.82	80	120	----	--	--	.23
		1	.89	1,075	1,613	4,301	6.00	1.50	.34
		2	.96	1,720	2,580	6,880	--	--	.46
3/4"	MW - 012	0	1.21	70	105	----	---	--	.39
		1	1.28	792	1,188	3,168	8.00	2.25	.59
		2	1.35	1,267	1,901	5,069	--	--	.79
1"	MW - 016	0	1.51	40	60	----	--	--	.53
		1	1.58	571	857	2,285	9.00	2.75	.75
		2	1.65	914	1,370	3,654	--	--	.98
1-1/4"	MW - 020	0	1.85	25	38	----	--	--	.76
		1	1.93	531	797	2,125	10.50	3.50	1.07
		2	2.02	850	1,274	3,398	--	--	1.37
1-1/2"	MW - 024	0	2.19	20	30	----	--	--	.84
		1	2.28	472	708	1,887	12.00	4.00	1.23
		2	2.37	755	1,133	3,021	--	--	1.63
2"	MW - 032	0	2.60	15	23	----	--	--	.90
		1	2.72	516	774	2,064	15.00	5.00	1.52
		2	2.84	826	1,239	3,302	--	--	2.14
2-1/2"	MW - 040	0	3.23	12	18	----	--	--	1.16
		1	3.33	387	581	1,548	20.00	8.00	1.86
		2	3.43	619	929	2,477	--	--	2.56
3"	MW - 048	0	3.78	10	15	----	--	--	1.21
		1	3.88	316	474	1,264	22.00	9.00	2.00
		2	3.98	506	758	2,022	--	--	2.80
3-1/2"	MW - 056	0	4.32	9	14	----	--	--	1.62
		1	4.45	297	445	1,188	24.00	10.00	2.61
		2	4.58	475	712	1,900	--	--	3.60
4"	MW - 064	0	4.85	8	12	----	--	--	1.69
		1	4.98	232	348	927	27.00	13.00	2.68
		2	5.10	371	557	1,485	--	--	3.68
5"	MW - 080	0	5.90	6	9	----	--	--	2.50
		1	6.03	191	286	764	31.00	18.00	3.75
		2	6.15	306	458	1,222	--	--	5.00
6"	MW - 096	0	6.87	5	8	----	--	--	3.47
		1	7.10	165	247	660	36.00	19.00	4.75
		2	7.33	264	396	1,056	--	--	6.04
8"	MW - 128	0	9.09	6	9	----	--	--	5.56
		1	9.19	234	350	934	40.00	20.00	9.44
		2	9.28	374	561	1,495	--	--	13.36
10"	MW - 160	0	11.18	5	8	----	--	--	6.80
		1	11.32	230	344	918	50.00	25.00	12.90
		2	11.45	367	551	1,469	--	--	19.00
12"	MW - 192	0	13.23	3	5	----	--	--	9.02
		1	13.37	161	241	643	60.00	30.00	14.83
		2	13.50	257	386	1,029	--	--	20.64

HEAVY DUTY HIGH PRESSURE HOSE

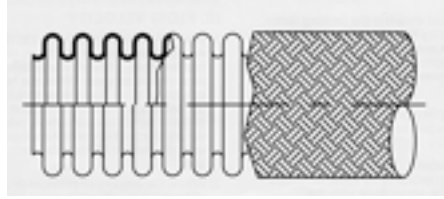

SERIES - HD Stainless Steel Hose

Construction: Annular/Close Pitch

Characteristics: Heavy Weight/Medium Flexibility

Material: Hose: T321, T316L

Braid: T304L

NOM. I D (IN.)	PART #	BRAID LAYERS	NOM. O D (IN.)	Max. Pressure @ 70°F(PSIG)			Centerline Bend Radius (IN.)		WEIGHT PER FT. (LBS.)
				WORKING	TEST	NOM. BURST	DYNAMIC	STATIC	
1/4"	HD - 004	0	.50	180	270	----	--	--	.09
		1	.57	2,562	3,844	10,250	5.00	1.00	.17
		2	.64	4,099	6,150	16,400	--	--	.26
3/8"	HD - 006	0	.67	100	150	----	--	--	.13
		1	.74	1,501	2,251	6,004	5.50	1.25	.25
		2	.81	2,401	3,602	9,604	--	--	.36
1/2"	HD - 008	0	.82	80	120	----	--	--	.39
		1	.92	2,194	3,291	8,777	8.00	1.50	.63
		2	1.02	3,510	5,265	14,040	--	--	.87
3/4"	HD - 012	0	1.21	70	105	----	--	--	.48
		1	1.31	1,311	1,967	5,244	8.00	2.00	.79
		2	1.41	2,098	3,147	8,392	--	--	1.10
1"	HD - 016	0	1.50	40	60	----	--	--	.79
		1	1.60	1,069	1,604	4,276	9.00	3.00	1.20
		2	1.70	1,710	2,566	6,840	--	--	1.61
1-1/4"	HD - 020	0	1.85	33	50	----	--	--	1.02
		1	1.97	1,110	1,666	4,443	10.00	3.25	1.66
		2	2.10	1,776	2,665	7,040	--	--	2.30
1-1/2"	HD - 024	0	2.17	20	30	----	--	--	1.36
		1	2.30	868	1,302	3,472	10.00	3.25	2.11
		2	2.43	1,388	2,082	5,552	--	--	2.86
2"	HD - 032	0	2.51	15	23	----	--	--	1.60
		1	2.64	810	1,215	3,240	11.50	5.38	2.56
		2	2.76	1,296	1,944	5,184	--	--	3.52
2-1/2"	HD - 040	0	3.23	10	15	----	--	--	2.00
		1	3.36	578	867	2,312	24.00	7.00	3.12
		2	3.49	925	1,387	3,700	--	--	3.30
3"	HD - 048	0	3.78	10	15	----	--	--	2.97
		1	3.91	540	810	2,160	28.00	7.50	4.42
		2	4.03	864	1,295	3,456	--	--	5.87
4"	HD - 064	0	4.81	8	12	----	--	--	3.10
		1	4.93	333	500	1,332	40.00	20.00	4.55
		2	5.05	533	800	2,132	--	--	6.00
6"	HD - 096	0	6.87	5	8	----	--	--	3.85
		1	7.10	266	398	1,062	48.00	24.00	6.45
		2	7.33	425	638	1,700	--	--	9.05



ULTRA HIGH PRESSURE HOSE

SERIES - HDX Ultra High Pressure

Construction: Annular/Close Pitch
 Characteristics: Heavy Weight/Medium Flexibility

Material: Hose: T316L
 Braid: T321 Double Braided

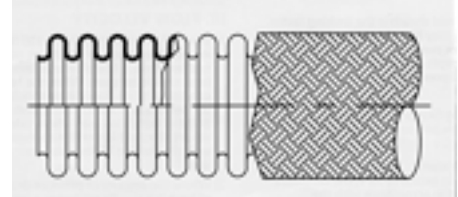

NOM. HOSE I D	HOSE TYPE	HOSE O D	WEIGHT PER FT.	MIN. LIVE LENGTH FOR VIBRATION	Minimum Bend Radius		MAX. WORKING PRESSURE @ 70°F	MAX. TEST PRESSURE	NORMAL BURST PRESSURE
					STATIC BEND	INTERMITTENT FLEXING			
1/4"	HDX - 04	0.63	0.39	4.25	2.00	8.25	5300	7950	21200
3/8"	HDX - 06	0.81	0.53	5.00	2.50	9.00	3900	5850	15600
1/2"	HDX - 08	1.05	0.75	6.00	3.00	10.50	3600	5400	14400
3/4"	HDX - 12	1.43	1.63	7.00	4.00	12.75	3550	5325	14200
1"	HDX - 16	1.75	2.07	8.25	5.25	15.00	2800	4200	11200
1-1/4"	HDX - 20	2.08	2.93	9.00	6.50	17.25	2480	3720	9920
1-1/2"	HDX - 24	2.41	3.62	10.00	8.00	19.50	2200	3300	8800
2"	HDX - 32	3.05	4.63	12.00	11.50	24.00	1675	2512	6700

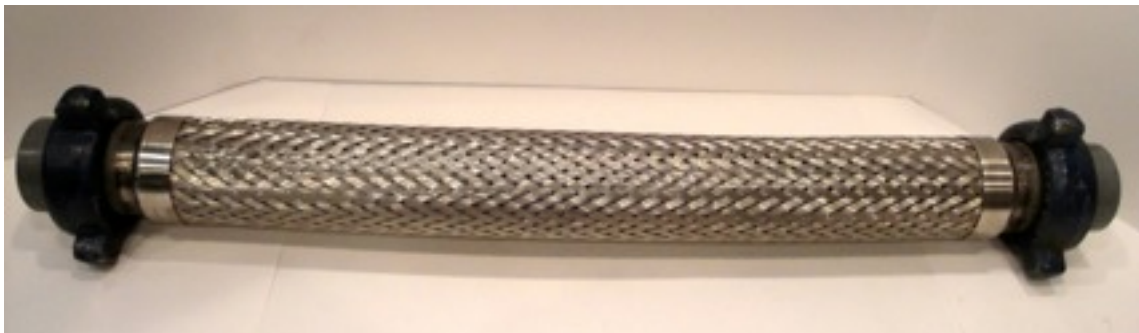



BRONZE HOSE

SERIES - BB Bronze Hose

Construction: Annular/Standard Pitch
 Characteristics: Medium Weight/Medium Flexibility

Material: Hose: Bronze
Braid: Bronze

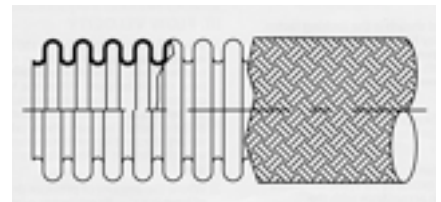

NOM. I D (IN.)	PART #	BRAID LAYERS	NOM. O D (IN.)	Max. Pressure @ 70°F(PSIG)			Center Bend Radius (IN.)		WEIGHT PER FT. (LBS.)
				WORKING	TEST	NOM. BURST	DYNAMIC	STATIC	
1/4"	BB - 004	0	.49	100	150	----	--	--	.13
		1	.57	1,035	1,553	4,142	5.50	1.00	.23
		2	.65	1,656	2,649	6,627	--	--	.33
3/8"	BB - 006	0	.67	40	75	----	--	--	.25
		1	.75	685	1,027	2,738	6.00	1.25	.36
		2	.83	1,096	1,644	4,381	--	--	.47
1/2"	BB - 008	0	.82	40	60	----	--	--	.38
		1	.90	706	1,059	2,825	7.00	1.50	.57
		2	.98	1,130	1,695	4,520	--	--	.76
3/4"	BB - 012	0	1.21	30	36	----	---	---	.50
		1	1.31	577	865	2,307	8.00	2.25	.83
		2	1.41	923	1,384	3,691	--	--	1.16
1"	BB - 016	0	1.51	20	30	----	--	--	.68
		1	1.61	470	705	1,881	10.00	3.00	1.12
		2	1.71	752	1,128	3,009	--	--	1.56
1-1/4"	BB - 020	0	1.85	15	23	----	--	--	.80
		1	1.95	361	541	1,443	12.00	3.50	1.31
		2	2.05	577	865	2,309	--	--	1.82
1-1/2"	BB - 024	0	2.18	10	15	----	--	--	1.03
		1	2.31	329	493	1,317	13.50	4.00	1.73
		2	2.43	526	789	2,107	--	--	2.43
2"	BB - 032	0	2.50	8	12	----	--	--	1.81
		1	2.63	317	475	1,267	17.00	5.00	2.73
		2	2.75	507	760	2,027	--	--	3.65
2-1/2"	BB - 040	0	3.18	8	12	----	--	--	1.39
		1	3.31	272	408	1,090	22.00	8.00	2.66
		2	3.43	435	653	1,744	--	--	3.93
3"	BB - 048	0	3.65	10	15	----	--	--	1.44
		1	3.78	201	301	805	24.00	12.00	2.84
		2	3.91	322	482	1,228	--	--	4.11
4"	BB - 064	0	4.81	8	12	----	--	--	3.45
		1	4.94	142	213	568	26.00	14.00	5.03
		2	5.06	227	341	909	--	--	6.61





UL LISTED STAINLESS STEEL HOSE ASSEMBLIES

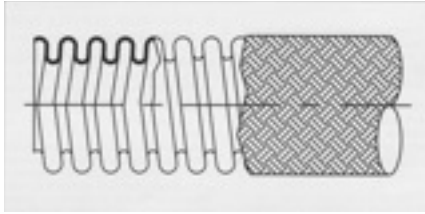

Stainless Steel Hose

Construction: Helical/Compressed Pitch

Material: Hose: 304 Stainless Steel

Braid: 304L Stainless Steel

For Compressed and Combustable Gases

Max Working Pressure 100 PSI

6M42

NOM. I D (IN.)	PART NUMBER	BRAID LAYERS	NOM. O D (IN.)	PRESSURE RATING @ 70°F WORKING	CENTERLINE BEND RADIUS (IN.)		WEIGHT PER FT. (POUNDS)
					DYNAMIC	STATIC	
3/8"	UL-006	1	0.66	150	5.50	1.00	0.21
1/2"	UL-008	1	0.80	100	6.50	1.50	0.25
3/4"	UL-012	1	1.07	100	8.00	1.50	0.37
1"	UL-016	1	1.37	100	8.75	1.75	0.53

End Fittings for UL Hose Assemblies:

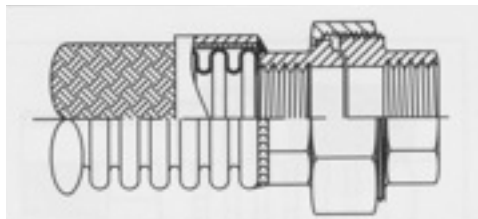

Welded Female Union

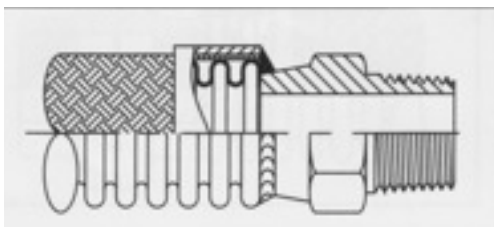

NPT Male Nipple with Internal Hex Nut

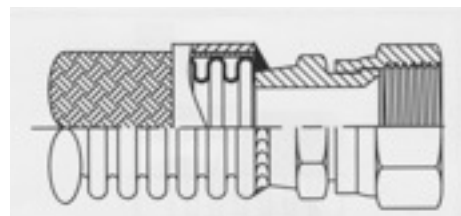

Welded JIC Swivel Female

CORRUGATED METAL HOSE FITTINGS

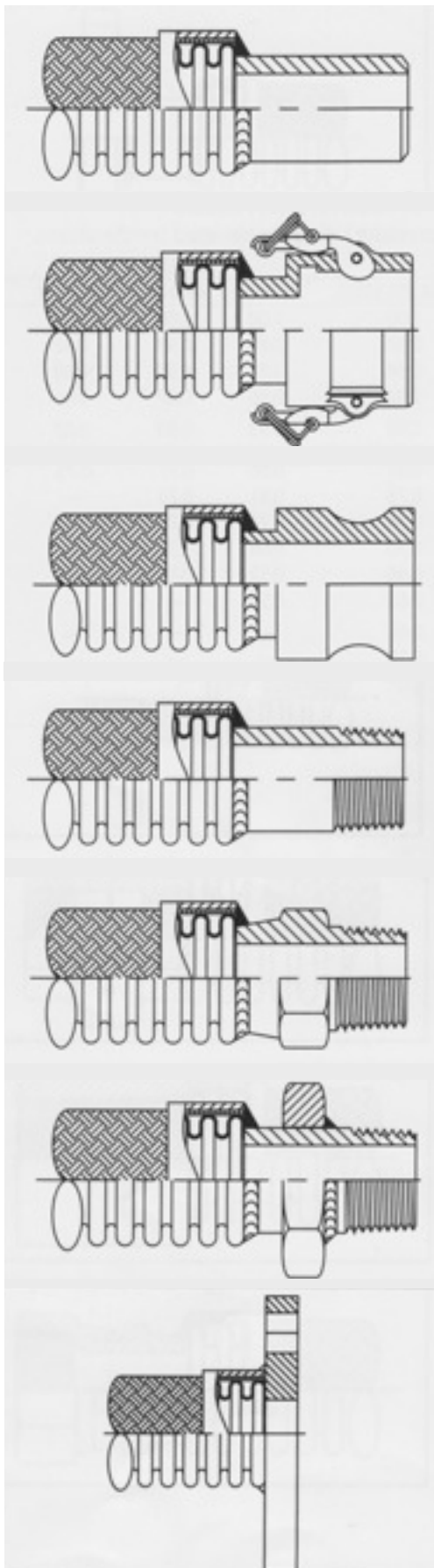

Welded Pipe End with 37-1/2 Degree Bevel

Size Availability: 1/8" diameter to 12" diameter

Material Availability: Carbon Steel, T304 and T316 Stainless Steel

Welded Quick Disconnect Female Part "D" Coupler

Size Availability: 1/2" diameter to 8" diameter

Material Availability: Carbon Steel and T316 Stainless Steel

Welded Quick Disconnect Male Part "A" Camlock

Size Availability: 1/2" diameter to 8" diameter

Material Availability: Carbon Steel and T316 Stainless Steel

Welded NPT Male Nipple

Size Availability: 1/8" diameter to 8" diameter

Material Availability: Carbon Steel, T304 and T316 Stainless Steel

NPT Male Nipple with Integral Hex Nut

Size Availability: 1/4" diameter to 2" diameter

Material Availability: Carbon Steel, T304 and T316 Stainless Steel

NPT Male with Welded on Hex Nut

Size Availability: 1/2" diameter to 4" diameter

Material Availability: Carbon Steel, T304 and T316 Stainless Steel

Welded Plate Flange ANSI Class 150 Drilling

Size Availability: 1/2" diameter to 12" diameter

Material Availability: Carbon Steel and Stainless Steel



CORRUGATED METAL HOSE FITTINGS

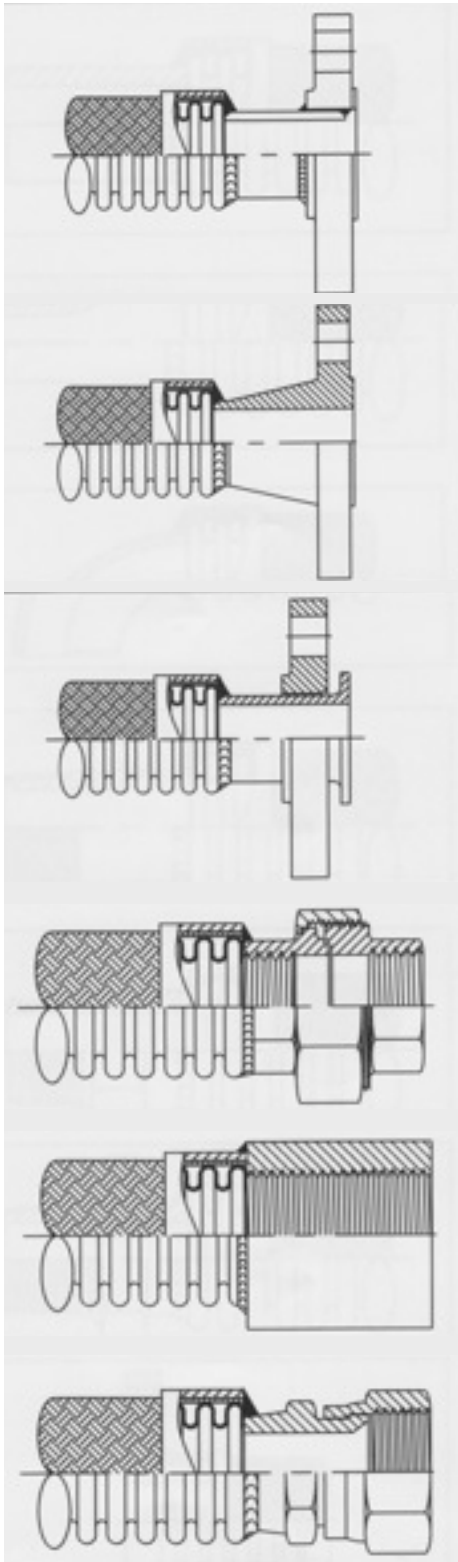

Raised Face Slip-On Flange with Pipe End

Size Availability: 1/2" diameter to 12" diameter

Material Availability: Carbon Steel, T304 and T316 Stainless Steel

ANSI Class Ratings: 150, 300, 600, 900, 1500

Welded Raised Face Weldneck Flange

Size Availability: 1/2" diameter to 12" diameter

Material Availability: Carbon Steel, T304 and T316 Stainless Steel

ANSI Class Ratings: 150, 300, 600, 900, 1500

Floating Flange with Type "C" MSS Stub End

Size Availability: 1/2" diameter to 12" diameter

Material Availability: Carbon Steel, T304 and T316 Stainless Steel

ANSI Class Ratings: 150, 300, 600, 900, 1500

Types "A", "B", and "C" stub ends are also available - call for details

Welded Female Union

Size Availability: 1/2" diameter to 4" diameter

Material Availability: Carbon Steel, T304 and T316 Stainless Steel

Pressure: 150, 300, 3000, 6000 pound

Welded Female NPT Half/Full Pipe Coupling

Size Availability: 1/2" diameter to 4" diameter

Material Availability: Carbon Steel, T304 and T316 Stainless Steel

Pressure: 150, 300, 3000, 6000 pounds

Welded JIC Swivel Female

Size Availability: 1/4" diameter to 2" diameter

Material Availability: Carbon Steel, T304 and T316 Stainless Steel

PROTECTIVE HOSE COVERINGS



Spring Guard

Spring guard reduces kinking and protects the hose from abrasion and rough handling.



Silicone Fire Sleeve

This fiberglass sleeving has a coating of silicone rubber bonded to it which offers flame resistance and has a continuous operating temperature of 500°F.



Nylon Sleeve

Woven nylon tubular sleeve is ideal for use as a protective covering and withstands temperature up to 275°F.



Heat Shrink Tubing

To minimize hose O D, heat shrinkable tubing is used in applications where cleanliness is essential. This provides easy cleaning of the outer hose surface.



Armor Guard

A highly flexible heavy duty interlocked metal casing to protect the hose against severe handling abuse and over bending. This can be applied over the entire length or in short sections at the end connection.



Selection Criteria

When selecting the correct flexible metal hose for a particular application the following must be considered:

- Temperature
- Pressure
- Media
- Size
- End Fittings
- Motion

When deciding on the best choice for a specific application, consider all the relevant operating factors against the properties of the various types of flexible metal hoses.

Temperature

Physical properties of any and all materials vary with temperature. Working pressure affects the limits of operating temperature, the material being conveyed and the nature of the application. Careful selection of material makes it possible to provide flexible metal hose for a wide range of operating temperatures. The choices of hose type, metal alloy, end fitting and fitting attachment method determine the temperature limit.

Pressure

The nominal pressure ratings of flexible metal hose does vary by type, material and size. Specific pressure ratings for types of flexible metal hose can be found in each section of this catalog. Under actual working conditions, pressure is affected by many other factors such as: pulse, temperature and bending stresses.

Media

For almost all applications, a metal hose can be selected that is resistant to the intended media. The media being conveyed must be carefully considered during the selection process. Metal hose is subject to corrosion from the material flowing through it as well as from the outside environment. Since metal hose is a thin-walled product, it will not have the same lifespan as a heavier walled tube or pipe of the same material.

Size

The size of flexible metal hose is specified by the nominal diameter. The existing piping will normally dictate the size of the metal hose for a particular application. Flow rate, velocity and pressure drop considerations may also influence the selection of the hose size.

End Fittings

The use of flexible metal hose is complimented by the extensive range of available end fittings. These end fittings may be: male or female pipe threads, unions, flanges, flared tube fittings other specially designed connectors. Depending on the type of hose and alloy used, end fittings are attached by: welding and silver brazing.

Motion

There are generally four types of applications where a flexible metal hose is used:

- To correct problems of misalignment.
- To provide flexibility in manual handling operations.
- To compensate for regular or constant movement.
- To absorb vibration.

In all types, careful hose selection, the design of the assembly and its installation are important for optimal service life. The flexibility of the hose used is determined by its mechanical design and the inherent flexibility of its material.

WARNING

Metal hose has a finite lifespan which is difficult to predict due to many contributing factors. We recommend hoses be inspected every six months for signs of wear, and replaced annually. In applications where hoses carry dangerous media or other critical applications we recommend hoses be inspected and replaced more frequently.

Notice: Should you be unable to determine a specification for a particular application, please call the factory with details describing the application so that we may make a recommendation. Because we do not supervise or control the installation and use of our products, *we cannot be responsible for their performance or for the improper application and usage of the data.*

Offset Chart



To determine required live length of an application, find the specific dynamic bend radius from the data sheets. Then locate that bend radius on the chart below. From the offset (Y) across the top of the chart, locate the amount of offset in inches. Read down to the bend radius row and the figure will be the live length required. For intermittent flexing, the offset motion should never be greater than 25% of the centerline bend radius. Should the offset exceed 25% use a loop.

For the minimum live length needed for normal industrial vibration only, use the bend radius of the selected hose and .25 inches of offset and read the minimum live length.

BEND RADIUS	Offset Y (inches)														
	0.25	0.50	0.75	1.0	1.25	1.50	2.0	2.50	3.00	4.00	5.00	6.00	8.00	10.00	12.00
0.50	0.9	1.3	1.7	2.0	2.3	2.6	3.2	3.7	4.2	5.3	6.3	7.3	9.4	11.4	13.4
1	1.3	1.8	2.3	2.6	3.0	3.4	4.0	4.6	5.2	6.3	7.4	8.5	10.6	12.6	14.7
2	1.8	2.5	3.1	3.6	4.1	4.5	5.3	6.0	6.7	8.0	9.2	10.4	12.6	14.8	17.0
3	2.1	3.0	3.8	4.4	4.9	5.4	6.3	7.2	7.9	9.4	10.7	12.0	14.4	16.7	19.0
4	2.5	3.5	4.3	5.0	5.6	6.2	7.2	8.1	9.0	10.6	12.0	13.4	16.0	18.4	20.8
5	2.8	3.9	4.8	5.6	6.3	6.9	8.0	9.0	9.9	11.7	13.2	14.7	17.4	20.0	22.4
6	3.0	4.3	5.3	6.1	6.8	7.5	8.7	9.8	10.8	12.6	14.3	15.9	18.8	21.4	24.0
7	3.3	4.6	5.7	6.6	7.4	8.1	9.4	10.5	11.6	13.6	15.3	17.0	20.0	22.8	25.5
8	3.5	4.9	6.0	7.0	7.8	8.6	10.0	11.2	12.4	14.4	16.3	18.0	21.2	24.1	26.8
9	3.7	5.2	6.4	7.4	8.3	9.1	10.6	11.9	13.1	15.2	17.2	19.0	22.3	25.3	28.1
10	3.9	5.5	6.8	7.8	8.8	9.6	11.1	12.5	13.7	16.0	18.0	19.9	23.3	26.5	29.4
12	4.3	6.0	7.4	8.5	9.6	10.5	12.2	13.6	15.0	17.4	19.6	21.6	25.3	28.6	31.7
14	4.6	6.5	8.0	9.2	10.3	11.3	13.1	14.7	16.2	18.8	21.1	23.2	27.1	30.7	33.9
16	4.9	6.9	8.5	9.8	11.0	12.1	14.0	15.7	17.2	20.0	22.5	24.7	28.8	32.6	36.0
18	5.2	7.4	9.0	10.4	11.7	12.8	14.8	16.6	18.2	21.2	23.8	26.2	30.5	34.4	37.9
20	5.5	7.8	9.5	11.0	12.3	13.5	15.6	17.5	19.2	22.3	25.0	27.5	32.0	36.1	39.8
22	5.8	8.1	10.0	11.5	12.9	14.2	16.4	18.3	20.1	23.3	26.2	28.8	33.5	37.7	41.6
24	6.0	8.5	10.4	12.0	13.5	14.8	17.1	19.1	21.0	24.3	27.3	30.0	34.9	39.2	43.3
26	6.3	8.8	10.8	12.5	14.0	15.4	17.8	19.9	21.8	25.3	28.4	31.2	36.2	40.7	44.9
28	6.5	9.2	11.3	13.0	14.5	15.9	18.4	20.6	22.6	26.2	29.4	32.3	37.5	42.2	46.5
30	6.7	9.5	11.6	13.5	15.1	16.5	19.1	21.4	23.4	27.1	30.4	33.4	38.8	43.6	48.0
35	7.3	10.3	12.6	14.5	16.3	17.8	20.6	23.0	25.3	29.3	32.8	36.0	41.8	46.9	51.6
40	7.8	11.0	13.4	15.5	17.4	19.0	22.0	24.6	27.0	31.2	35.0	38.4	44.5	50.0	55.0
45	8.2	11.6	14.3	16.5	18.4	20.2	23.3	26.1	28.6	33.1	37.1	40.7	47.2	52.9	58.2
50	8.7	12.3	15.0	17.3	19.4	21.3	24.6	27.5	30.1	34.9	39.1	42.8	49.6	55.7	61.2
55	9.1	12.9	15.8	18.2	20.3	22.3	25.8	28.8	31.6	36.6	40.9	44.9	52.0	58.3	64.1
60	9.5	13.4	16.4	19.0	21.3	23.3	26.9	30.1	33.0	38.2	42.7	46.9	54.3	60.8	66.8

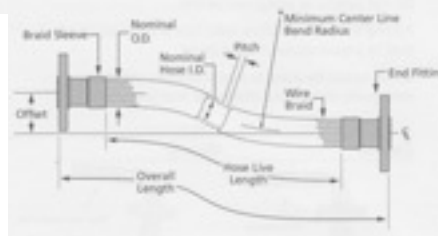



Temperature Adjustment Factors

The strength and thereby the pressure rating of metal hose decreases as the temperature increases. As the operating temperature of a metal hose assembly increases, the maximum allowable working pressure of the assembly decreases. The pressure ratings shown in the specifications charts for corrugated and interlocked hose are valid at 70°F. Elevated service temperatures will decrease these pressure ratings by the factors shown in the following chart for the alloy used in the braid wire. What also must be considered is the maximum working temperature of the end fittings, of the hose and their method of attachment.

For example to calculate the maximum working pressure for:

- 3/4" ID, 321 stainless steel corrugated hose
-
- with single-braided, 304L braid
-
- at 800°F.

From the corrugated metal hose specification table, the maximum working pressure at 70°F is 792 PSIG. Multiply 792 PSIG by 0.73. The maximum working pressure at 800°F is 578 PSIG.

Temperature Adjustment Factor Based on Braid Alloy

TEMPERATURE (°F)	304/304L STAINLESS STEEL	316L STAINLESS STEEL	321 STAINLESS STEEL	MONEL	BRONZE
70	1.00	1.00	1.0	1.00	1.00
150	0.95	0.93	0.97	0.93	0.92
200	0.91	0.89	0.94	0.90	0.89
250	0.88	0.86	0.92	0.87	0.86
300	0.85	0.83	0.88	0.83	0.83
350	0.81	0.81	0.86	0.82	0.81
400	0.78	0.78	0.83	0.79	0.78
450	0.77	0.78	0.81	0.77	0.75
500	0.77	0.77	0.78	0.73	----
600	0.76	0.76	0.77	0.72	----
700	0.74	0.76	0.76	0.71	----
800	0.73	0.75	0.68	0.70	----
900	0.68	0.74	0.62	----	----
1,000	0.60	0.73	0.60	----	----
1,100	0.58	0.67	0.58	----	----
1,200	0.53	0.61	0.53	----	----
1,300	0.44	0.55	0.46	----	----
1,400	0.35	0.48	0.42	----	----
1,500	0.26	0.39	0.37	----	----

Pressure Loss

For the same flow characteristics, the pressure loss is higher in metal hoses than rigid piping, due to the profile of the corrugations. As a rough estimation, expect the pressure loss in corrugated hoses to be 150% higher than in new, smooth steel pipes.

Classification of Motion

Random Motion

This motion is not predictable and occurs from the manual handling of a hose assembly. Care must be taken to prevent over-bending of the hose and to avoid external abrasion of the wire braid. An armor covering of interlocked hose provides protection against these abuses.

Axial Motion

This motion occurs when there is extension or compression of the hose along its longitudinal axis. This type of motion is restricted to unbraided corrugated hose only and is accommodated by traveling loops or bellows specifically designed for this purpose.

Angular Motion

This motion occurs when one end of a hose assembly is deflected in a simple bend with the ends not remaining parallel.

To find the live hose length:

$$L = \pi R \varnothing 180 + 2(s)$$

L = Live Hose Length (inches)

$\pi = 3.1416$

R = Minimum Centerline Bend Radius -- Dynamic (in.)

$\varnothing =$ Angular Deflection (degrees)

S = Outside Diameter of Hose

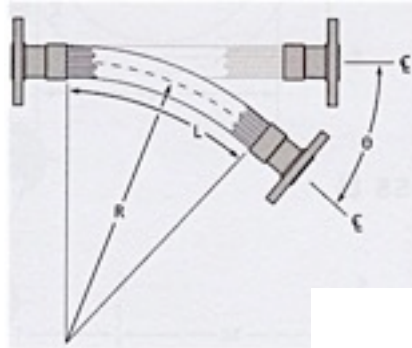

Offset Motion

Offset motion occurs when one end of the hose assembly is deflected in a plane perpendicular to the longitudinal axis with the ends remaining parallel. This movement can be due to a one-time (static) bend or movement which repeatedly occurs slowly over time (such as thermal expansion).

- The appropriate formula to use to calculate Live hose Length depends on the condition of the moving end.
- When the offset motion occurs to both sides of the hose centerline, use total travel in the formula; i.e., 2 x "T".
- The offset distance "T" for constant flexing should never exceed 25% of the centerline bend radius "R".
- If the difference between "L" and "Lp" is significant, exercise care at installation to avoid stress on hose and braid at the maximum offset distance.

L = Live Hose Length (inches)

Lp = Projected Live Hose Length (inches)

R = Minimum Centerline Bend Radius -- Dynamic (in.)

T = Offset Motion to One Side of Centerline (inches)

PRESSURE AND MOTION

Flow Velocity Consideration

The flow velocity in corrugated metal hose should never exceed 150 ft./sec. for gas or 75 ft./sec. for liquids. When a hose is installed in a bent condition, the flow values should be reduced proportionally to the degree of the bend. Where the flow velocity exceeds these rates, an interlocked metal hose liner or larger hose I.D. is recommended.

Minimum Bend Radius Occurs at Offset Position

Moving end is free to move "out of line" at neutral position. To find the live hose length:

$$L = \sqrt{6(RT) + T^2}$$

$$Lp = \sqrt{L^2 - T^2}$$

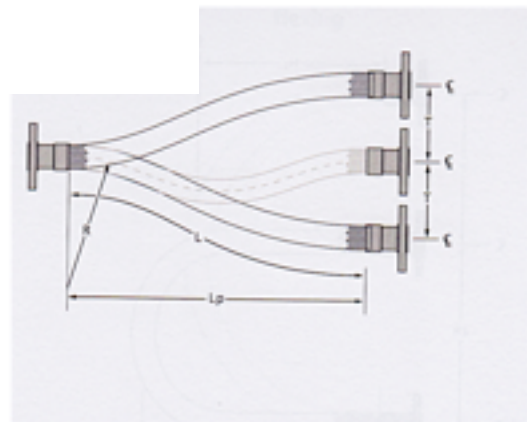
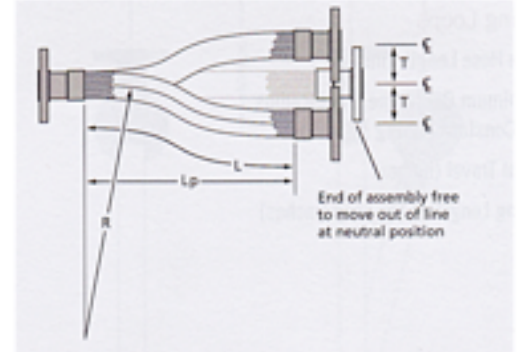

Minimum Bend Radius Occurs at Crowded Position

Moving end of hose is restricted to move only up and down as hose crosses neutral position.

To find the live hose length:

$$L = \sqrt{20(RT)}$$

$$Lp = \sqrt{L^2 - T^2}$$





Traveling Loops

In a piping system accommodating axial movement or where the magnitude of the motion exceeds the limits of an offset movement, the traveling loop configuration is the ideal solution. In traveling loops, the centerline of a hose assembly is bent in a circular arc. Traveling loops can accommodate movement in one of two ways. A constant radius traveling loop accommodates motion by varying the length of the arms of the assembly while the radius remains constant. A variable radius traveling loop accommodates motion by varying the bend radius of the hose assembly. Both of these types of traveling loops can be installed to absorb either horizontal or vertical movement. The constant radius traveling loop provides for greater movement while the variable radius traveling loop requires less installation space.

Traveling Loops

- L = Live Hose Length (inches)
- R = Minimum Centerline Bend Radius for Constant Flexing (inches)
- T = Total Travel (inches)
- H = Hang Length of the Loop (inches)

Constant Radius Traveling Loop - Class A

$$L = 4R + T/2$$

$$H_1 = 1.43R + T/2$$

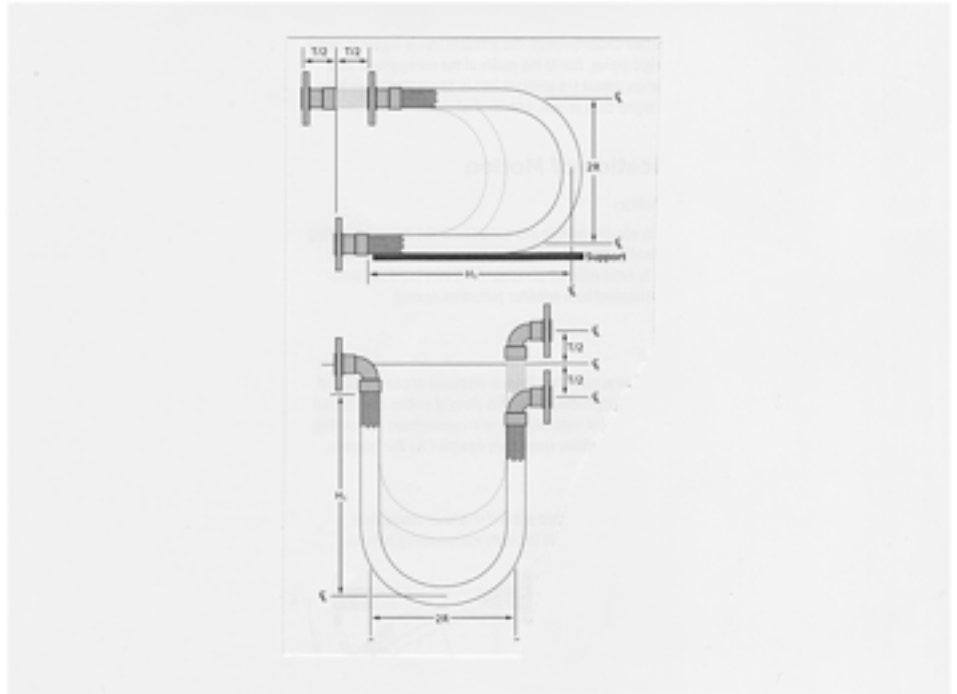

Variable Radius Traveling Loop - Class B

$$L = 4R + 1.57T$$

$$H_1 = 1.43R + 0.79T$$

$$H_2 = 1.43R + 0.5T$$

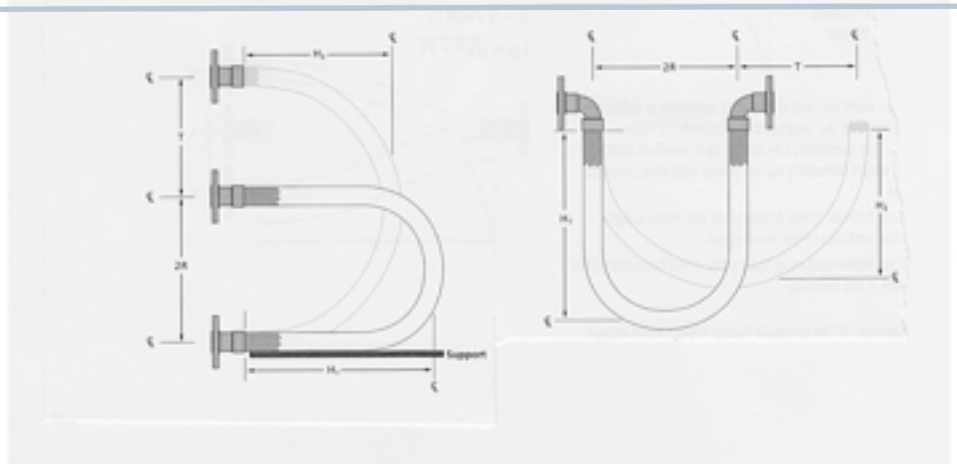

In Plane Traveling Loop



Corrugated hose is engineered to provide maximum service life when properly installed. Improper installation, incorrect flexing or careless handling in an application will reduce the effective service life of the hose and cause premature failure of an assembly. The following installation and handling precautions should be observed to achieve optimum performance from your corrugated hose assemblies.

Avoid torque

Do not twist the hose assembly during installation when aligning the bolt holes in a flange or in making up pipe threads. The utilization of lap joint flanges or pipe unions minimize this condition. It is recommended that two wrenches be used in making the union connection; one to prevent the hose from twisting and the other to tighten the coupling.

In plane lateral offset installation

Prevent out-of-plane flexing in an installation. Always install the hose so that the flexing takes place in only one plane. This plane must be the plane in which the bending occurs.

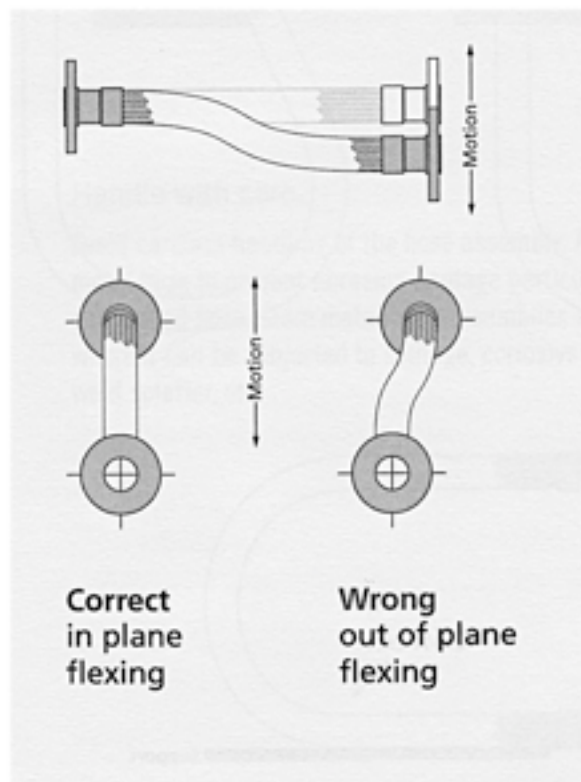
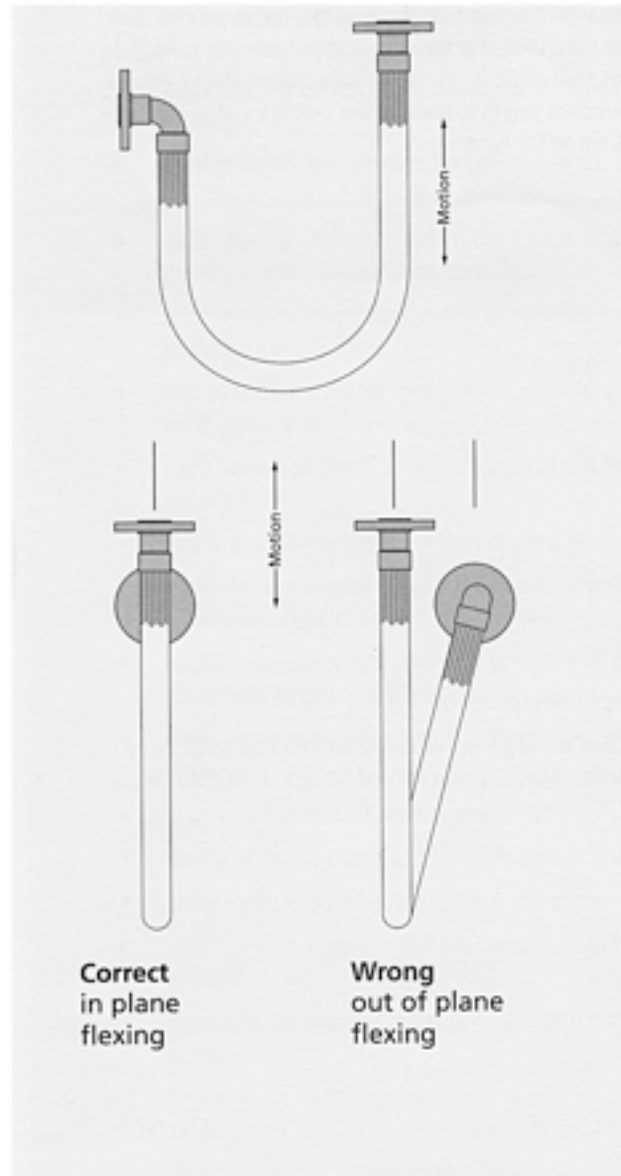



Avoid over bending

The repetitive bending of a hose to a radius smaller than the radius listed in the specification tables for corrugated hose will result in premature hose failure. Always provide sufficient length to prevent over bending and to eliminate strain on the hose.

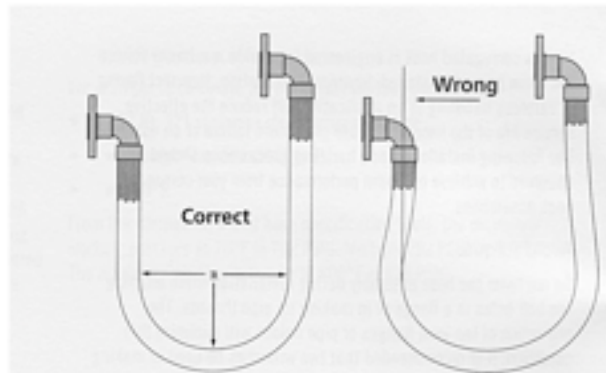

Avoid sharp bends

Utilize sound geometric configurations that avoid sharp bends, especially near the end fittings of the assembly.

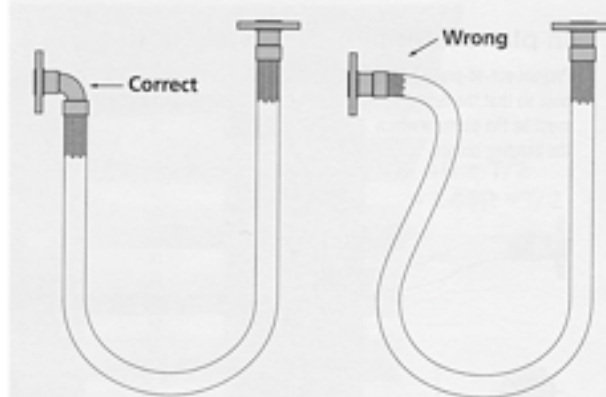

Provide support

When installing the assembly in a horizontal loop, provide support for the arms to prevent the hose from sagging.

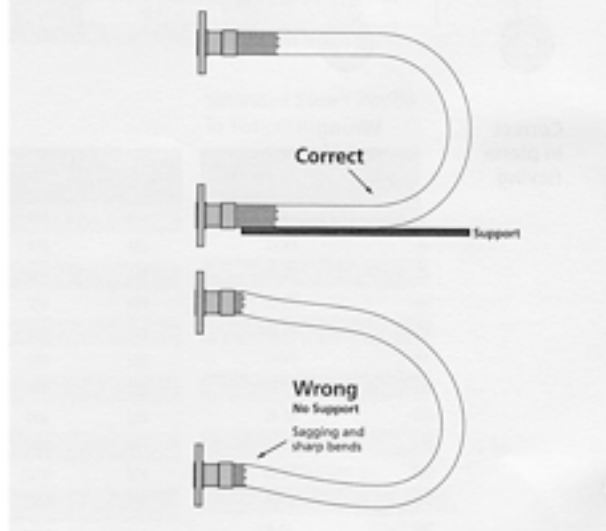



Do not extend or compress axially

A piping system which uses metal hose to absorb movement must be properly anchored and/or guided.

Always support the piping to prevent excessive weight from compressing the hose and relaxing the braid tension.

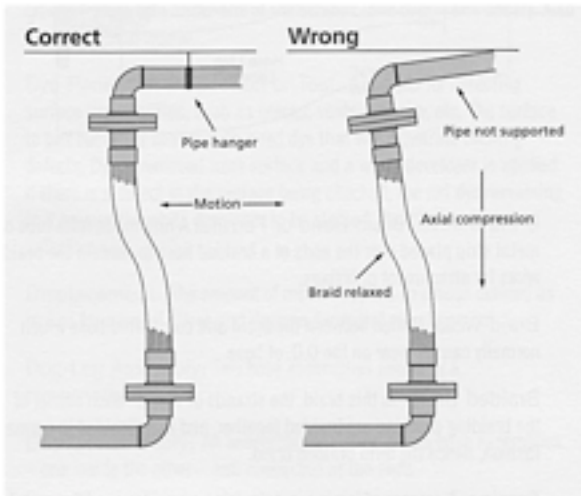

Handle with care

Careless handling of the hose assembly must be avoided. Always lift or carry metal hose to prevent abrasion damage particularly to braided corrugated hose. Store metal hose assemblies away from areas where it can be subjected to spillage, corrosive fumes or sprays, weld splatter, etc.

Do...

- follow any printed instructions with the flexible connector.
- follow industry-recommended practices and use care in handling and installing flexible connector.
- install flexible connectors so that the bend is as close to the center of the connector as possible.
- observe the minimum bend radius as specified by the connector manufacturer.
- trial-fit threaded connections by hand, unmake and then make permanent.
- use a flexible connector of proper length to suit the installation.
- only wrench on the fitting hex flats as provided.
- design the installation to allow for ground movement after installation, such as settling or frost heave.
- install the proper length connector to allow 2" straight run of hose at each end fitting.
- use pipe wrenches on both mating hexes to avoid twisting the hose.
- keep hose free from all objects and debris.
- handle and store connectors carefully prior to installation.
- check for leaks before covering the installation.
- install in such a manner that the connector can be removed.
- make sure the pressure rating of connector is not exceeded.

Don't...

- apply a wrench to a hose, collar or assembly.
- twist hose assemblies during installation or when aligning the bolt holes in a flange or when making up pipe threads.
- "pre-flex" a flexible connector to limber up. Over-bending could cause damage and result in leakage.
- over-bend a flexible connector. A 45°-90° bend should be sufficient to install any flexible connector.
- install a flexible connector with the bend next to the end fittings. This could cause damage and result in leakage.
- lay the flexible connector on rocks or objects which could puncture the hose and cause leakage.
- attempt to stretch or compress a flexible connector to fit an installation.
- restrict flexibility by allowing connector to come into contact with other components or equipment during installation.

PLEASE CALL THE FACTORY (800-642-4673) IF YOU HAVE ANY QUESTIONS OR CONCERNS ABOUT YOUR APPLICATION.



INTERLOCKED FLEXIBLE METAL TUBING



Type UI is heavy duty, flexible tubing. Tubing sizes range from 1/4" to 6" ID with special diameters made to order. Tubing constructed of galvanized, stainless steel, and aluminum interlocking strips from .010" to .012" ID. Soldered, brazed, or welded on pipe nipples with fittings desired to fill any requirements. Tubing normally furnished unpacked, but packings may be ordered.

FLOPPY TUBING

Available for many applications

- Armor casing
- BOP
- Conveyor hose for dust, lint, sawdust, etc.
- Shielding conduit
- Steam Hose Liner

SPECIFICATIONS

Type UI available in Aluminum, Galvanized Steel, and Stainless Steel

Unpacked - fully interlocked flexible tubing
.010" - .012" Metal

NOMINAL I D	NOMINAL O D	INSIDE* BENDING DIAMETER	APPROXIMATE WEIGHT "C" FEET	NOMINAL I D	NOMINAL O D	INSIDE* BENDING DIAMETER	APPROXIMATE WEIGHT "C" FEET
1/4"	.375"	3"	11	----	----	----	----
3/8"	.500"	4"	14	2-1/8"	2.280"	15-1/2"	72
1/2"	.625"	6"	16	2-1/4"	2.410"	16-1/2"	76
5/8"	.750"	6-1/2"	18	2-3/8"	2.530"	17-1/2"	81
3/4"	.875"	6-1/2"	20	2-1/2"	2.660"	18-1/2"	85
7/8"	1.000"	7"	24	2-3/4"	2.910"	20"	93
1"	1.130"	7-1/2"	28	2-7/8"	3.030"	21"	97
1-1/8"	1.260"	8-1/2"	32	3"	3.160"	22"	102
1-1/4"	1.380"	9-1/2"	36	3-1/4"	3.410"	24"	110
1-3/8"	1.510"	10"	38	3-1/2"	3.660"	26"	118
1-1/2"	1.650"	11"	48	3-3/4"	3.910"	27"	127
1-5/8"	1.780"	12"	52	4"	4.160"	29"	135
1-3/4"	1.900"	13"	58	4-1/2"	4.660"	33"	152
1-7/8"	2.030"	14"	60	5"	5.170"	37"	168
2"	2.160"	15"	66	6"	6.170"	44"	200

Specifications for other sizes not shown are available on application.

*Tubing is available with various packings which will increase the inside bending diameter.

Midwest Flexible Hose also offers the following products:

Stainless Steel Expansion Joints

Teflon® Expansion Joints

Rubber Expansion Joints

Composite Hose Assemblies

Adaptor Fittings

Please call the factory for more
information **1-800-642-4673**





Distributed by:

Phone: 800-642-4673

Fax: 262-781-2398

e mail: tom@midwestflexiblehose.com

5181 N. 125th St., P.O. Box 249 Butler,
WI 53007